

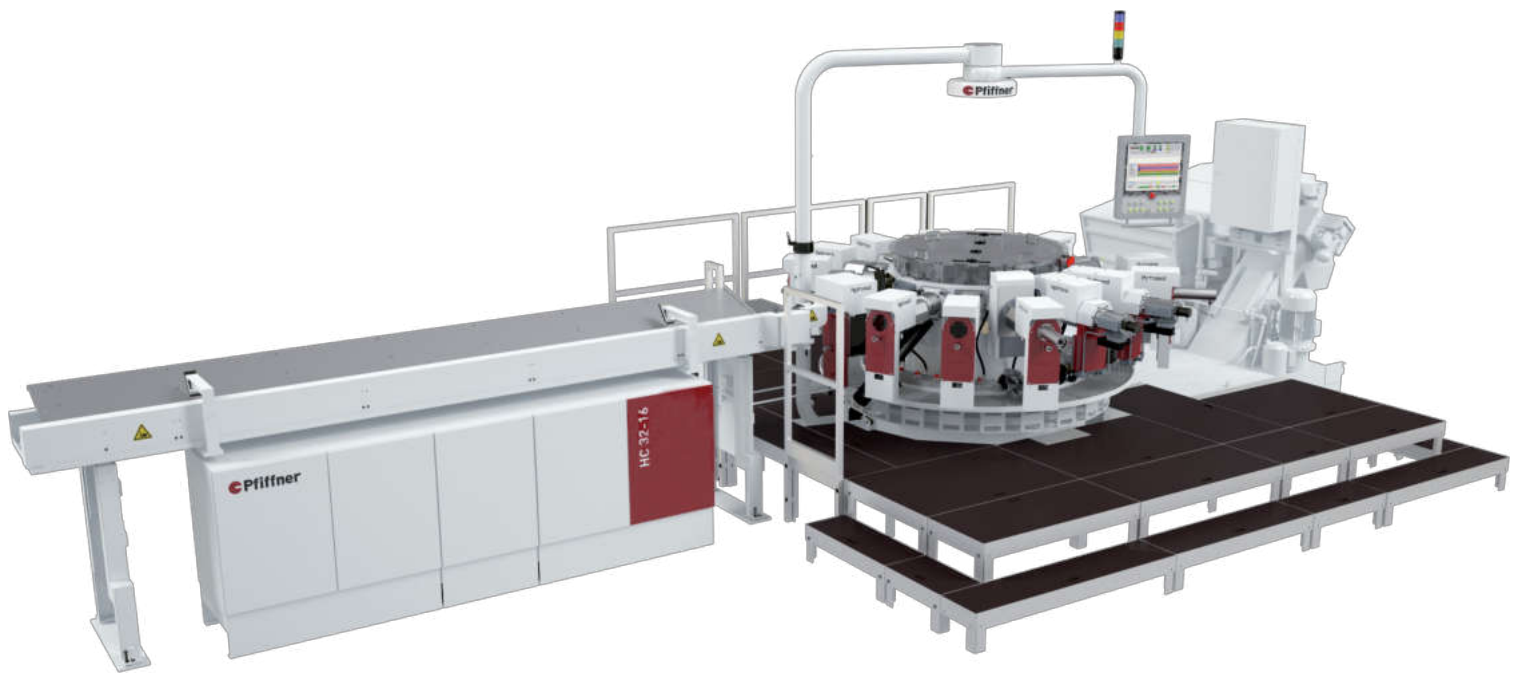

# ROTARY TRANSFER MACHINES HYDROMAT® HC PRODUCT LINE *EPIC<sup>plus</sup>*

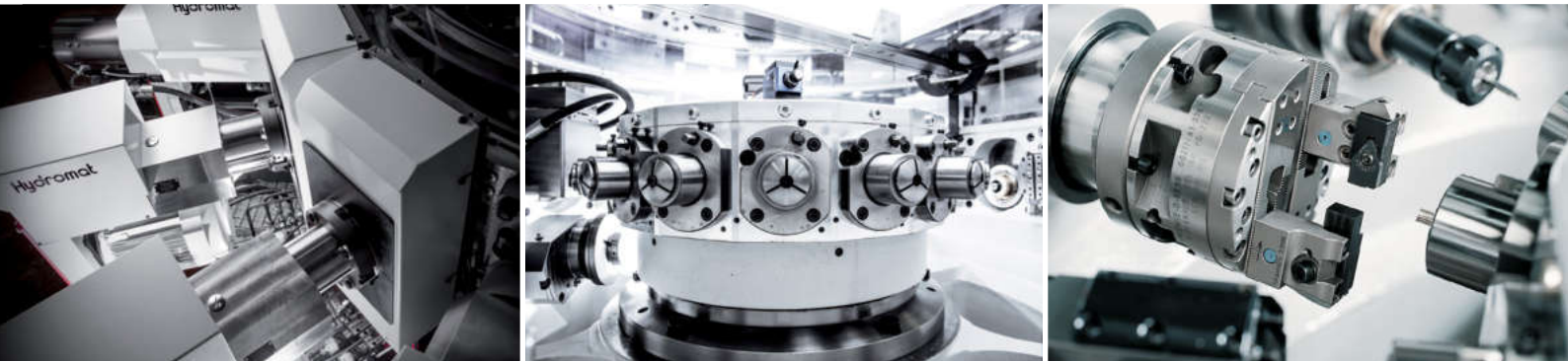

Precise | Productive | Reliable



# The FFG Rotary Transfer Platform

## Flexible Multi-Machining with Hydromat®

**Precise, modular and efficient: The FFG group is the world's leading manufacturer of rotary transfer machines and offers the best solutions for workpieces at the high volume end.**

United under the roof of the FFG group: with the rotary transfer machines of the tradition brands IMAS, Pfiffner and Witzig & Frank, you are always one cycle ahead.

The rotary transfer machine program covers all applications for the serial production of complex metal parts. Rotary transfer machines are designed for the handling of bar and coil materials, or automatic part feeding. They guarantee high-precision machining of each workpiece, being carried out simultaneously on each station. Every rotary transfer machine is specified, built for, and customised to the pieces it will process.

The ability to set up working stations horizontally as well as vertically allows big machining jobs with the highest output just-in-time. The enormous flexibility of the rotary transfer machines gives our clients a major advantage in dealing with the growing challenges of today's global markets:

- ▶ The most cost-effective solutions
- ▶ Maximum precision and process reliability in mass production
- ▶ High investment security thanks to extensive modularity
- ▶ High reusability thanks to reconfigurable machine systems
- ▶ High flexibility and variability (simpler retooling, reduced setup times)
- ▶ High machine availability
- ▶ Low maintenance costs (TCO)
- ▶ Turnkey solutions
- ▶ Process optimisation
- ▶ Global after sales management

### Sequential machining

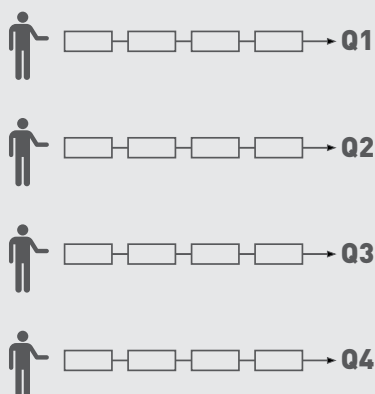

- ▶ 4 people
- ▶ 4 varying qualities
- ▶ 4 interfaces
- ▶ 4 x larger footprint

### Simultaneous machining on rotary transfer machines:

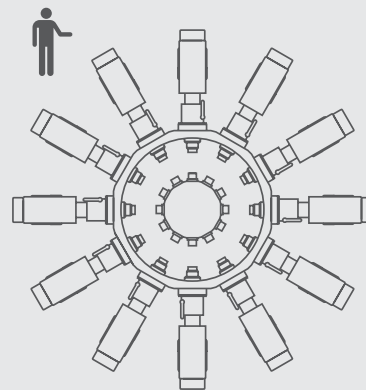

- ▶ Faster
- ▶ More precise
- ▶ More productive
- ▶ More reliable



**Highest profitability for you!**



# Rotary Transfer Machine

## HC 25-12 / HC 45-12 / HC 52-12

## HC 32-16 / HC 45-16

### Faster, better, EPIC<sup>plus</sup>

On the Hydromat rotary transfer machines from the Pffnner HC product line EPIC<sup>plus</sup>, up to 24 machining units can be utilised for fully-automated and simultaneous operation.

This allows the process sequence to be individually and optimally structured. The result: the shortest cycle times and highest output rates at a consistently high quality. The world leader in productivity.

### Highlights

- ▶ Easily reconfigurable machine system
- ▶ 100% CNC machine with Bosch MTX control
- ▶ Minimal setup times
- ▶ Modular and configurable unit concept
- ▶ Highest productivity (machine availability)
- ▶ Lowest maintenance costs

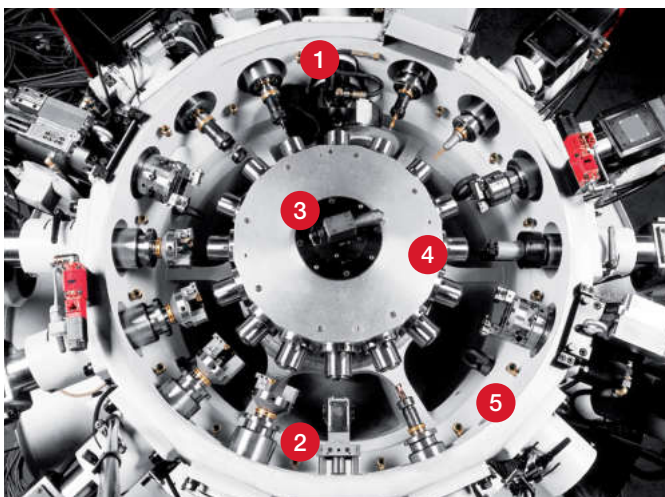
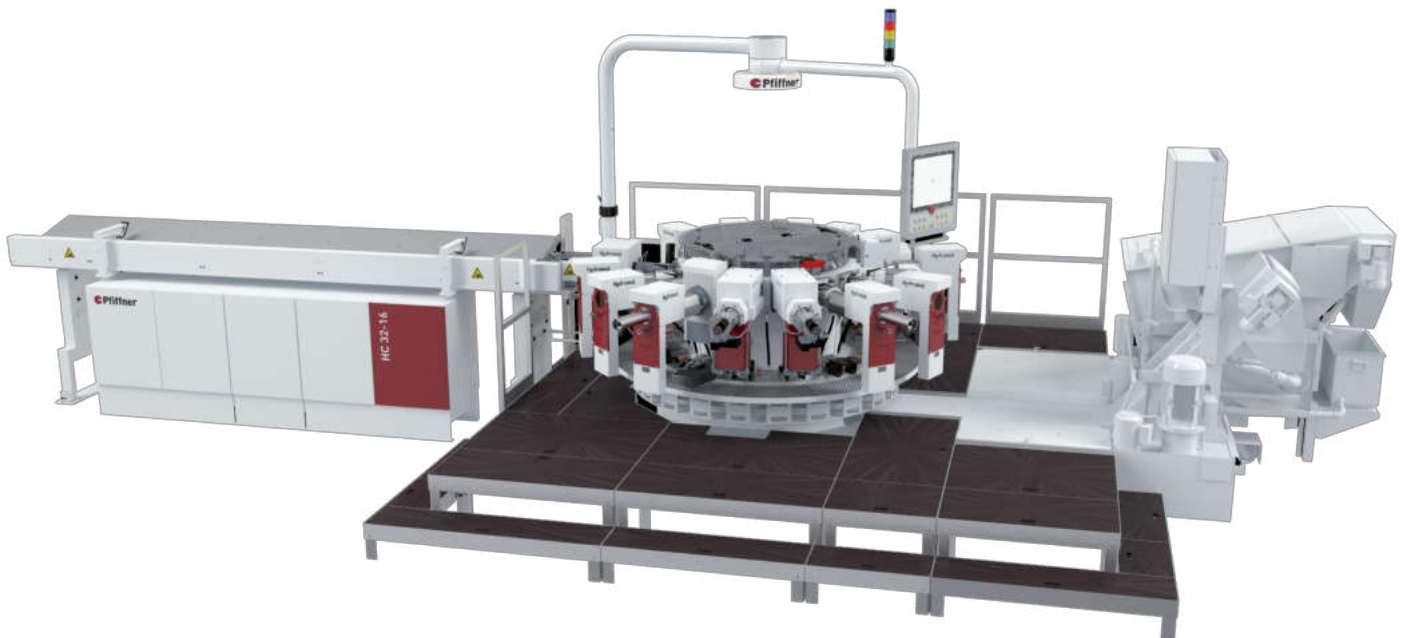

- 1 Cutting unit
- 2 Inverting unit for machining from 2 sides
- 3 Indexing table for workpiece transportation
- 4 Collet/chuck
- 5 Unit carrier for stable attachment of units

A look at the Hydromat machine HC 32-16

# Rotary Transfer Machine with Swivel Chuck

## HC 12-U

## HC 16-U

### 5-sided machining for maximum flexibility

The types HC 12-U and HC 16-U rotary transfer machines fulfil the highest machining requirements. In addition to the Hydromat®-specific rotary indexing table, the machines are also equipped with swivelling hydraulic high-precision indexing chucks. The 12 or 16 chucks can be freely indexed: Therefore, machining from 5 sides is also possible without having to re-clip the workpiece.

The hydraulic chucks are specifically adjusted to the workpiece to be clamped. The clamping pressure is hydraulically variably adjustable. As a result, cubic workpieces with edge lengths up to 120 mm or bars with diameters of 52 mm and lengths of 200 mm can be machined without any problems. The HC 12/16-U are ideally suited for cast blanks, profile material and bars.

### Highlights of the HC-U product line

- ▶ Easily reconfigurable machine system
- ▶ 100 % CNC machine with MTX control
- ▶ Minimal setup times
- ▶ Modular and configurable unit concept
- ▶ Highest productivity (machine availability)
- ▶ Lowest maintenance costs
- ▶ Machining from 5 sides in one clamping

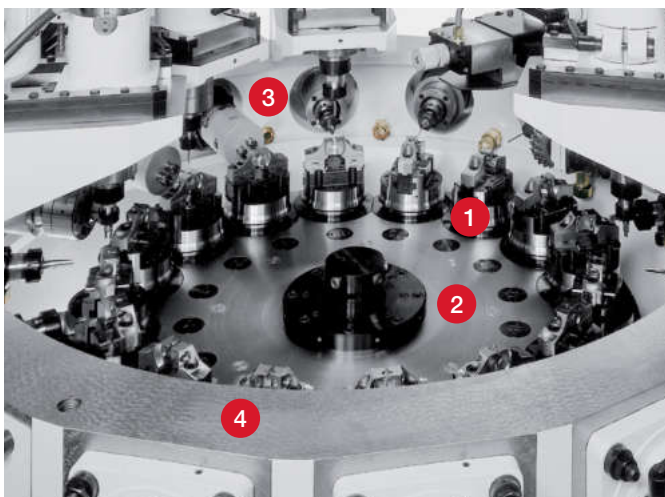
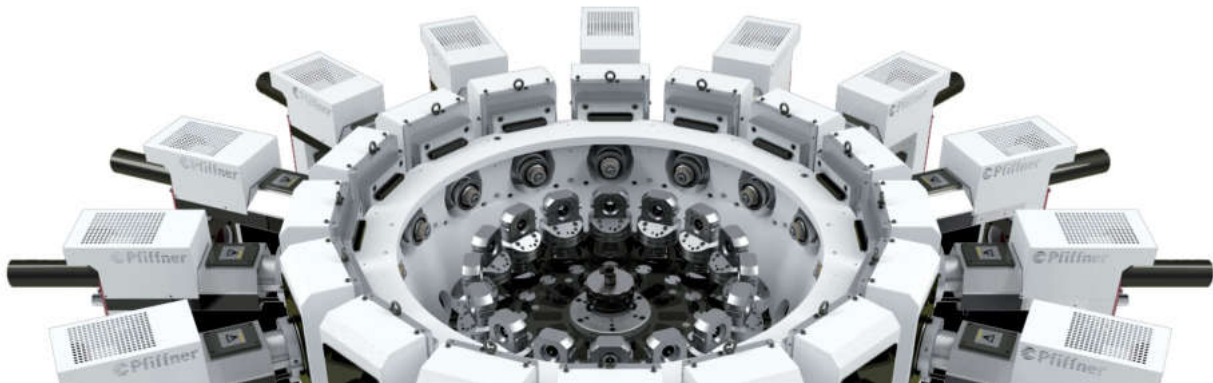

- 1 Chuck
- 2 Indexing table for workpiece transportation
- 3 Support for the inclusion of vertical units
- 4 Unit carrier for stable attachment of units

A look at the Hydromat HC 16-U

# Investment Security through Modularity

## The Pfiffner Modular Concept

### The Hydromat modular principle

The structure and equipment of Pfiffner machines are primarily determined by the workpiece to be machined. The modular concept guarantees high flexibility in the future: The Hydromat® machining units are interchangeable with regard to size and all the stations are individually configurable up to 4 axes.

The machine control and the new user interface reflect the mechanics of the machine's control and operating concept, which are consistently based on modularity and flexibility. All the axes can be individually configured and interpolated via efficient bus systems. This highly flexible system provides the foundation for an efficient setup of the machine during part replacement.

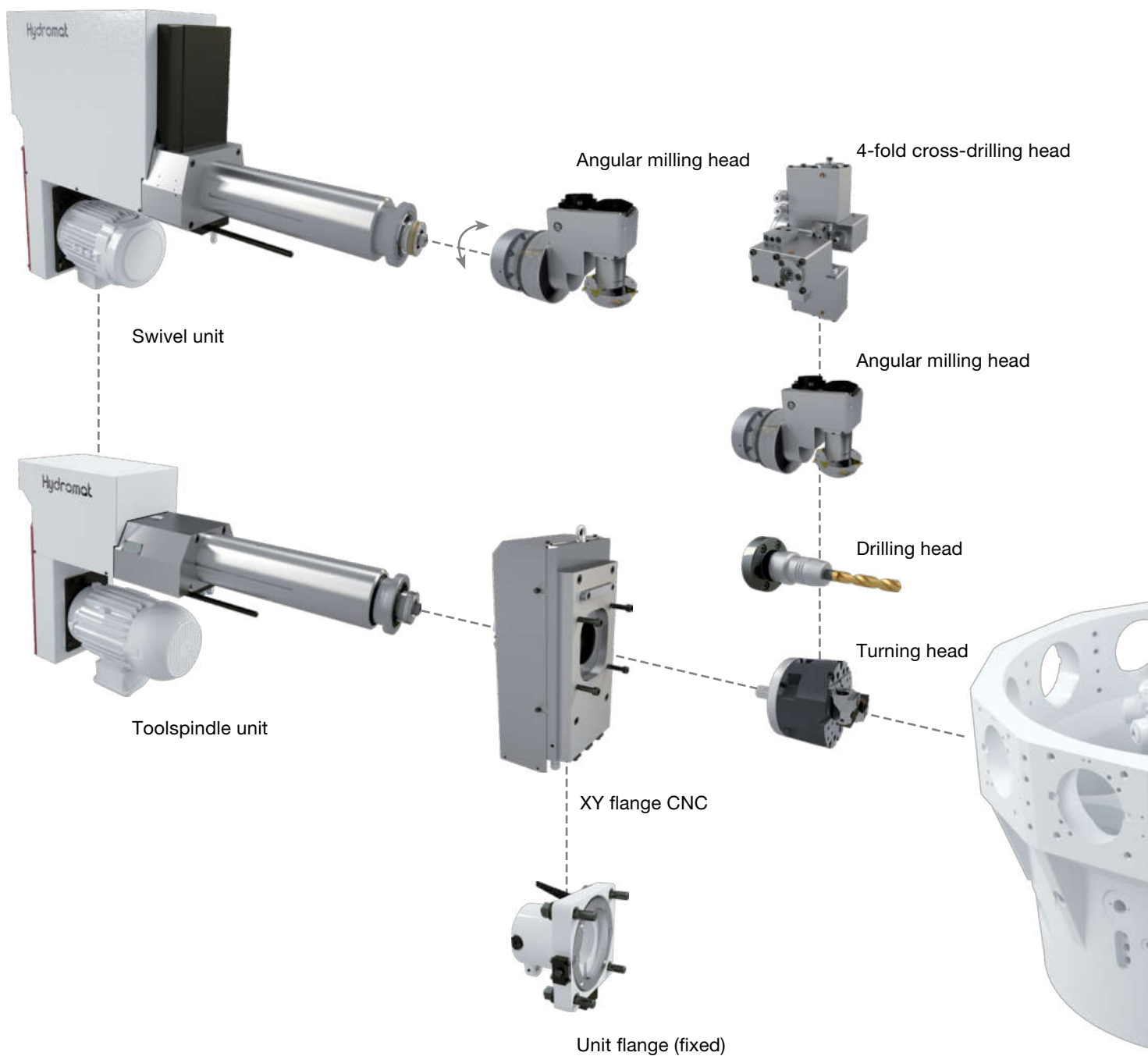



Collet

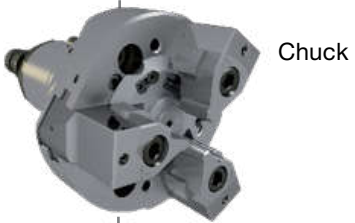

Chuck

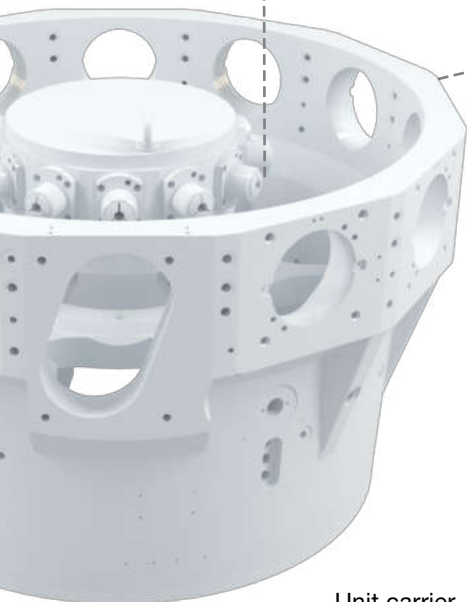

Unit carrier

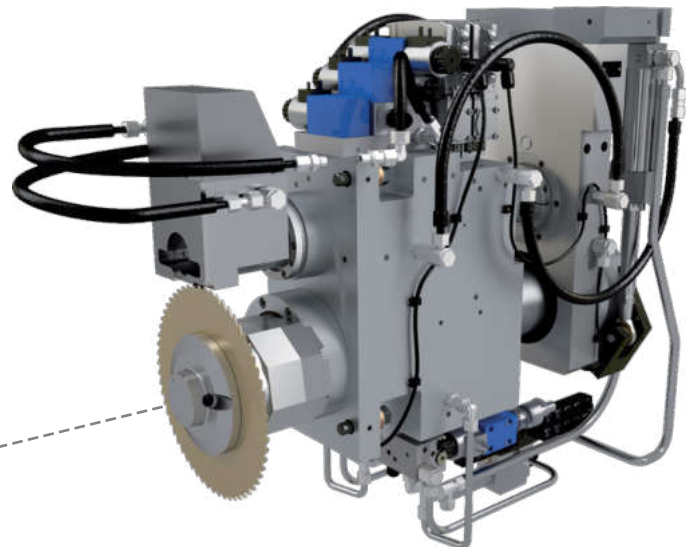

Cutting unit

Facing head with single slide



Facing head with twin slide



Turning unit



Inverting unit

# Ready for your Application

## HC Product Line Loading Variants

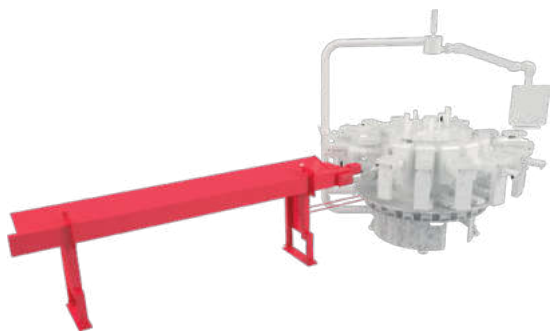

### Bar feeder and saw

Dimension: for 3 m to 6 m bar  
 Different cross sections possible  
 Autonomy: approx. 8 - 16 h  
 (supporting surface 350 / 500 mm wide)

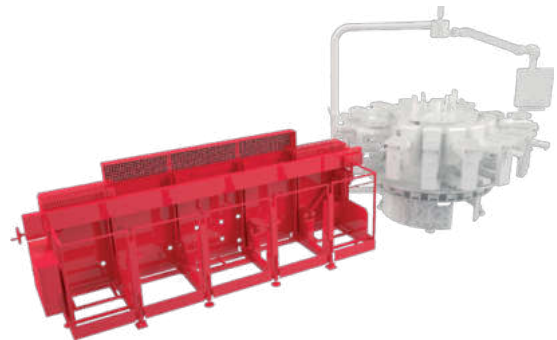

### Bundle loader and saw

Dimension: for 3 m to 4 m bar  
 Loading up to 2 tonnes in a bundle possible  
 Autonomy: approx. 3 shifts (24 h)

from bar



### Spiral conveyor and load handling

For blanks as bulk material feed  
 Automatic orientation within the conveyor  
 Autonomy: approx. 1 shift (8 h)

from blank



### Loading robot (6-axis robot)

Double gripper for a quick loading and unloading,  
 possible on one station  
 Ideal for linking multiple machines  
 Autonomy: fully automated process

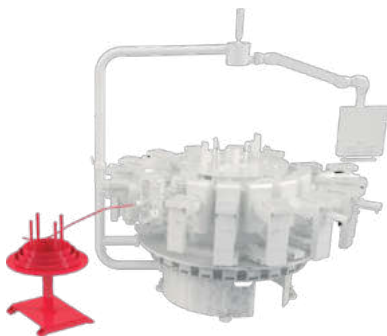

### From the coil (decoiler) and saw

Design incl. wire straightening device  
 Round material up to Ø 10 mm  
 Autonomy: approx. 3 shifts (24 h)

from wire

### Machining from the bar, coil, or with automated part feeding

As customer needs are always the priority at Pffner, each Pffner rotary transfer machine is configured and optimised in accordance with individual customer specifications. Together with the customer, we determine the perfect material feeding variant either from bar, blank or wire for the most economical serial production of a complete workpiece family. As a result, we completely integrate our production line into the value chain.



# The New Control System

## Bosch Rexroth IndraMotion MTX advanced

### Innovative, flexible, future-proof

Until now, there had been no CNC control available on the market that could control so many axes. The challenge lies in being able to combine decentralized intelligent electric and electro-hydraulic axes in any configuration.

So far, we had to use multiple CNC control systems in parallel using the so-called master-slave process. Within engineering, this was extremely time-consuming and expensive. For our machines, and consequently for our customers, this was no ideal technical solution with regard to operability and cycle times. With the IndraMotion MTX advanced, an individual CNC control can control up to 99 axes and 25 NC channels.

The CNC control also boasts outstanding processing power and a high storage capacity.

The drive-internal safety functions of the IndraDrive drives make it possible to create a modular safety concept. The intelligent servo drives and the control cabinet-free IAC Multi Ethernet control integrated within the valve close the control circuit decentrally.

The efficient control hardware for all axes and the integrated PLC reduce cycle times, therefore increasing productivity. At the same time, they simplify operation and reduce the time to change to new products. In addition, our customers can also change the machine configuration themselves. They have the option to independently add or remove the functions of a unit. The new machine software impresses with its high degree of modularity.



A look at the new compact control cabinet

### Control with 99 axes/25 channels

- ▶ Higher allocation speed
- ▶ Simpler and faster operability and programming
- ▶ Savings of time and money
- ▶ >10% performance increase

### Decentralization = flexibility

- ▶ Scalable and modular control system
- ▶ Technically expandable to 99 axes
- ▶ Reconfigurable machine system
- ▶ Mechanically and electrically a homogeneous modular system
- ▶ High reusability and therefore high investment security

### Everything from a single source: the CNC control as well as the drive technology

- ▶ Long-term product care
- ▶ Long-term reusability
- ▶ Long-term support services
- ▶ Partnership for even higher customer satisfaction



Rexroth IndraControl L85, Source: Bosch Rexroth AG



Rexroth IAC-Multi-Ethernet control valve

# Industry 4.0

## The Challenge within Production

### The fourth Industrial Revolution

In recent years, production has been oriented towards the principles of lean production, increased flexibility and therefore the achievement of significant success with regard to productivity and supply capability. With Industry 4.0, modern production is on the cusp of a radical upheaval. As the leading rotary transfer machine manufacturer, Pfiffner is ready to take this step into the future together with its customers and implement key new developments.

### Information in the right place, at the right time

For Pfiffner, this primarily means making use of modern comprehensive information and communication technology in order to increase productivity. Requirements such as real-time capability of production data and simple production system diagnoses can be smartly and intelligently implemented. With Pfiffner production systems, the “fourth Industrial Revolution” is practically within reach!

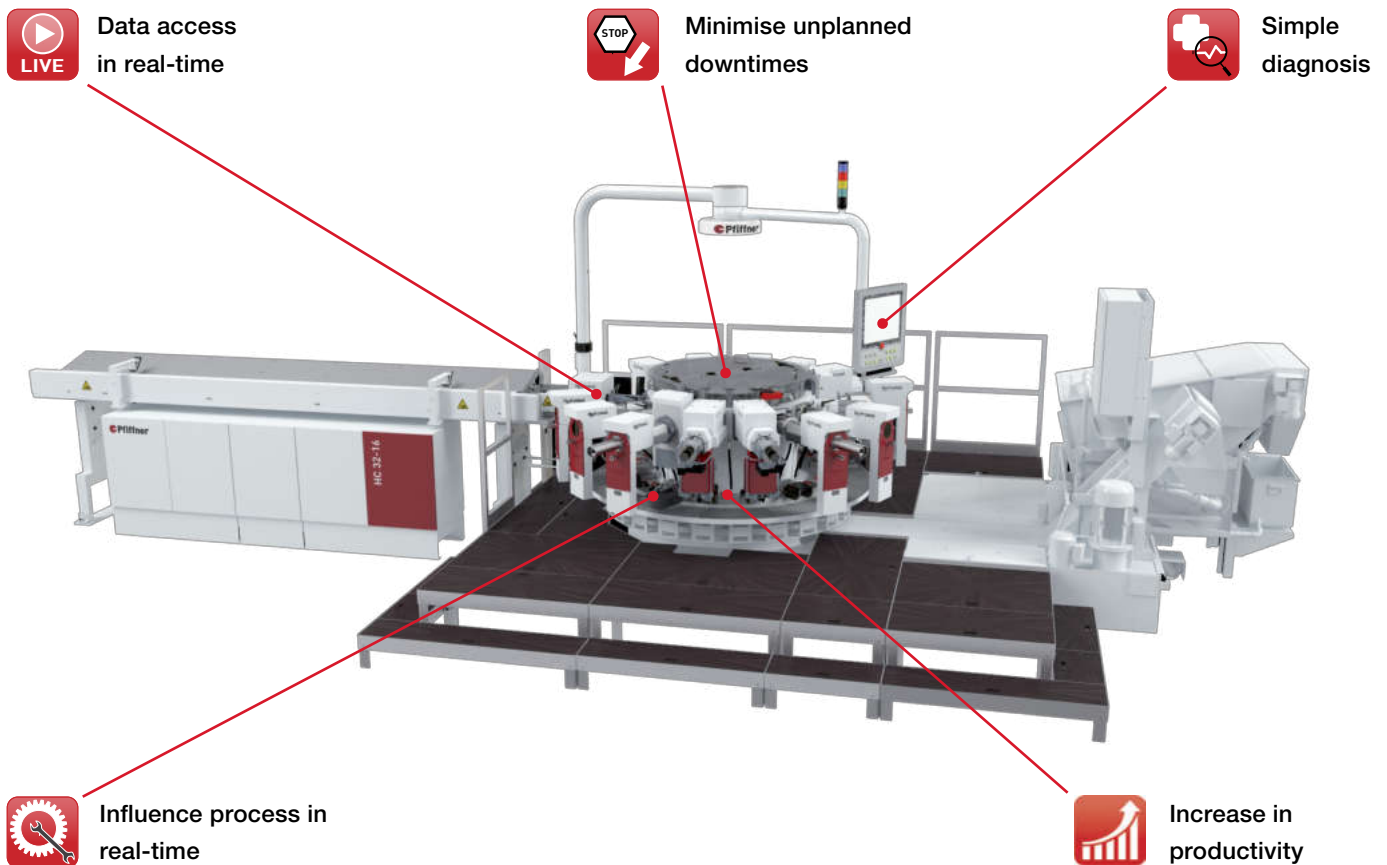

The Pfiffner concept for Industry 4.0 is the use of the IoT Gateway from Bosch Rexroth for machines with IndraMotion MTX. Data is made available via the umati (universal machine tool interface) interface. umati is an initiative of VDW (German Machine Tool Builders' Association). It is a uniform interface that allows the secure, smooth and effortless integration of machine tools and plants into customer and user-specific IT ecosystems.

The control, drive and sensor data is recorded via OPC-UA and pre-processed. Selected data can optionally be displayed via a web interface. In the end, the data for other IT systems (MES, PPS, data analytics...) is made available via an umati server using OPC-UA<sup>1</sup>.

<sup>1</sup> Uniform language for the “real-time coupling” of machines

# Industrie 4.0

## Our Approaches for your Benefit and Added Value

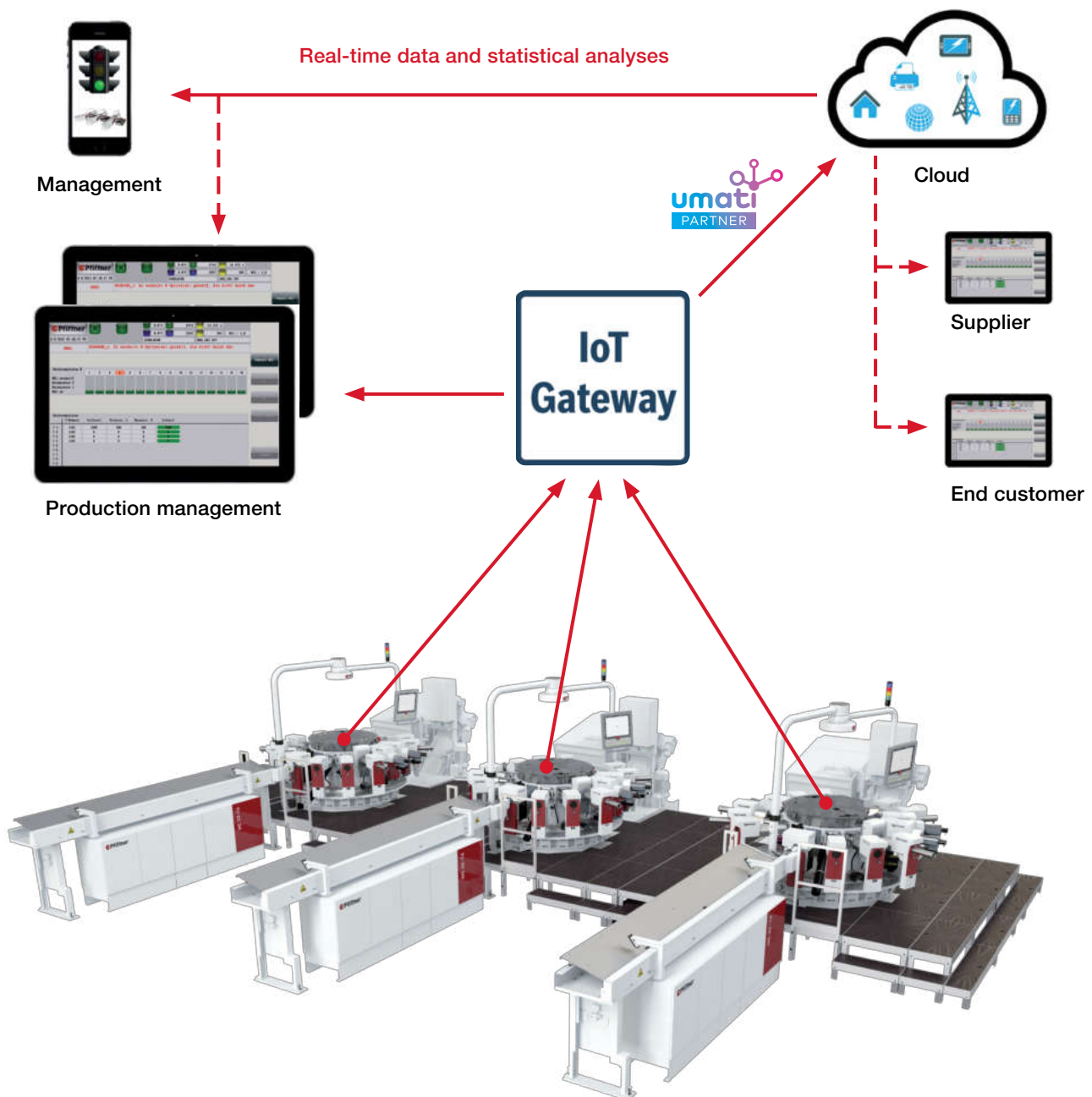

### Compiling and recording data

- ▶ Recording and analysis of machine data
- ▶ Web-based visualisation
- ▶ Use of standardised interfaces

### Machine state monitoring

- ▶ Working mode, cycle times and counter
- ▶ Machine availability

### Machine diagnostics

- ▶ Predictive maintenance

### Safer remote access

- ▶ Use of proven IoT cloud security
- ▶ Safer access via current Internet connection

# Service, Support and Consultation from a Single Source

The great trust that customers have placed in the Pfiffner group throughout its over 45-year history is an obligation. The development of individual solutions is based on the close and cooperative partnership with customers all around the world. In addition to the individual equipping of rotary transfer machines as well as the straightforward support provided during the conversion of a machine, the fast delivery of spare parts and short reaction times in the event of machine faults round off Pfiffner's scope of offers with needs-oriented gloss. Thanks to the use of state-of-the-art telecommunications technology, the significance of the teleservice is now even greater. Cheap and efficient remote diagnoses support the seamless functioning of the Pfiffner rotary transfer machines.

## An overview of our support services:

### Service calls

- ▶ Provision of a service call within 24 h of initial telephone contact
- ▶ Telesupport via VPN for Pfiffner rotary transfer machines

### Repairs

- ▶ Qualified repairs with functional tests of units, spindles and valves at Pfiffner locations

### Spare parts

- ▶ Central storage facility with high availability of parts
- ▶ Competent point of contact for consultation and sales

### Customer training

- ▶ Operator training
- ▶ Maintenance training (mechanical and electrical)
- ▶ Programming training
- ▶ Individual customer training according to requirement profile

### Inspection agreements

- ▶ Maintenance and service costs decrease, production quality and planning security

### Turnkey solutions with initial process engineering

### Feasibility and chip removal attempts

### Process optimisation, installed base

(over 2600 machines in use worldwide)

### Modernisation, installed base (ReVest® & tuning kits)

(visit [www.pfiffner.com](http://www.pfiffner.com) for additional information, videos, etc.)

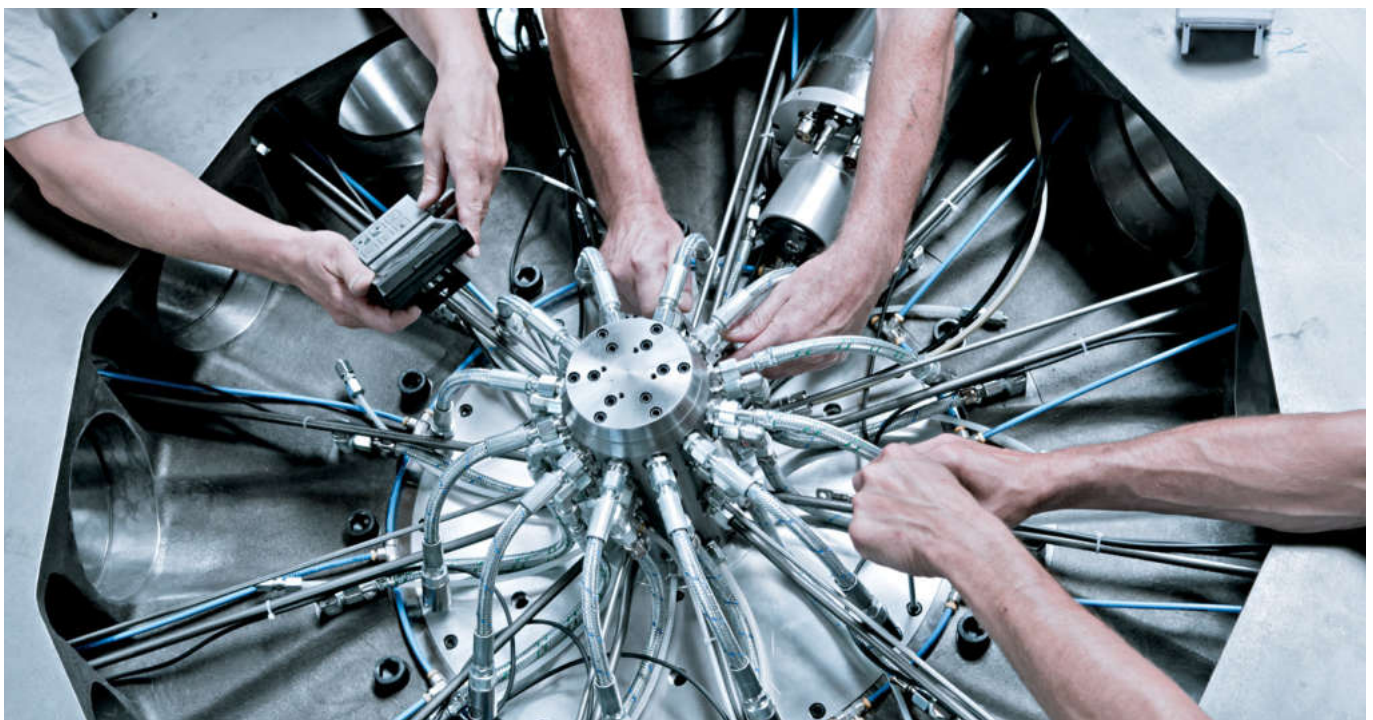



83% of all customers use more than one Pfiffner rotary transfer machine.  
(Source: View of the production hall of Rosenberger Hochfrequenztechnik GmbH & Co. KG)

# We are at Home in Many Industries

The possibility of manufacturing highly complex workpieces quickly, cheaply and at high quantities is a key factor for success.

As a result, Pfiffner Hydromat® rotary transfer machines have been successfully used within numerous different quality-oriented industries.

## Application examples:



**Cycle time:** 9.6 sec.  
**Material:** Sint C30-E



**Cycle time:** 10.5 sec.  
**Material:** 9SMnPb28

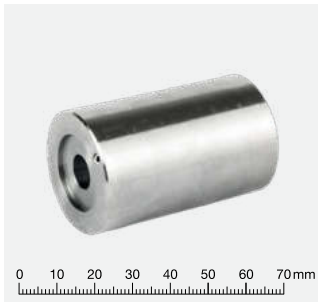

**Cycle time:** 13 sec.  
**Material:** ST52-3



**Cycle time:** 12.5 sec.  
**Material:** 1.4301



**Cycle time:** 8.5 sec.  
**Material:** AlSiMg



**Cycle time:** 9.5 sec.  
**Material:** AlSiMgMnT6



**Cycle time:** 12.5 sec.  
**Material:** 1.4301



**Cycle time:** 10 sec.  
**Material:** 38SMn28



**Cycle time:** 12.3 sec.  
**Material:** 1.4307



**Cycle time:** 11.7 sec.  
**Material:** 1.4301

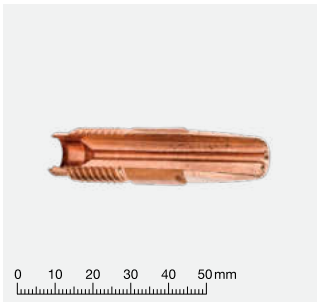

**Cycle time:** 4.5 sec.  
**Material:** CuCrZr



**Cycle time:** 4.0 sec.  
**Material:** MS58



**Cycle time:** 5.6 sec.  
**Material:**  
Hexagon 11SMnPb30



**Cycle time:** 8.0 sec.  
**Material:** 1.4301



**Cycle time:** 9.3 sec.  
**Material:** 11SMn30+C



**Cycle time:** 7.5 sec.  
**Material:** 9SMnPb36K

# Endless Possibilities

The proven technology of the Pfiffner Hydromat® rotary transfer machines allows highly profitable and complete machining of all serial parts, from the simplest to the most complex. The application possibilities are limitless. Intelligent procedures

ensure maximum precision and allow shorter setup times through duplicate settings. Universal application areas employing modular machining stations support the development of challenging and future-oriented solutions.

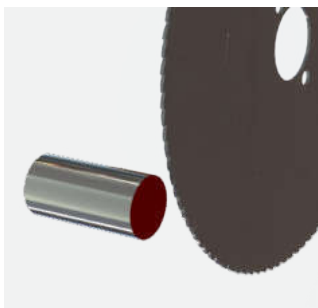

Sawing off a bar part

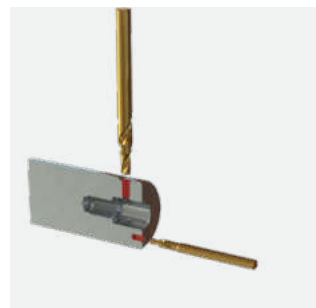

Simultaneous pilot drilling and cross drilling



Simultaneous drilling and milling

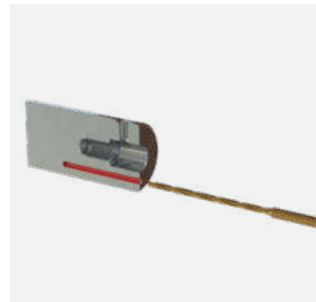

Deep-hole boring



Threading cutting

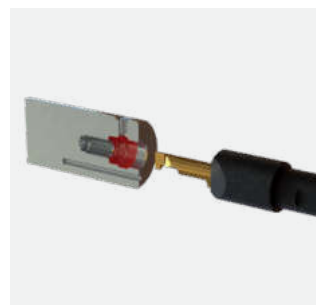

Turning an inner contour

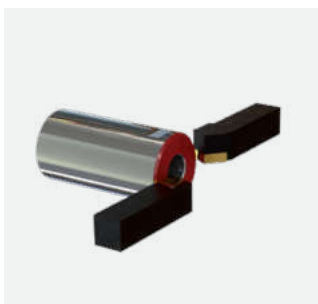

Face turning and chamfering



Cross drilling, internal deburring (spoon deburring)





**Inverting**



**Inclined cross drilling**

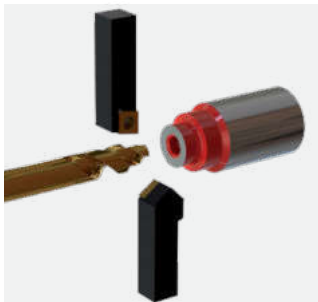

**Simultaneous turning and drilling**



**Threading milling**

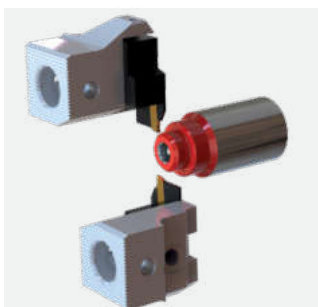

**Recessing**



**Milling a slot or contour**



**Hexagon wobble broaching**



**Hexagon punching or milling**



Hydromat

Hydromat



Hydromat  
2004  
AG 2-000

# Overview

## Hydromat® HC Product Line *EPIC<sup>plus</sup>*



### Efficient spindle drives

40% of the total power consumption is taken up by industry. 65% of this is consumed by motors. Through improved energy efficiency of the speed-regulated drives, this consumption can be reduced by up to 50%. A further benefit is the flexibility to meet new requirements.



### Ready for the future

The Pfiffner I4.0 solution provides our customers with an overview of the state of the machine and an improved planning capability for maintenance and repairs. Condition monitoring is not only used to reduce downtime times, but also to guarantee process quality.



### 100% CNC

Rotary transfer machines have never been this flexible before. Being able to react quickly to changing requirements provides you with the decisive competitive edge.

A safe investment in the future!



### Everything under control

Pfiffner sets the course: Setup mode and diagnostics displays are available at all times for a fast and targeted error analysis. As a result, your Hydromat® will be working in perfect sync and with maximum precision at a record time.



### Minimal setup times

Shorter product life cycles and increasing part diversity require a rapid retooling process. Thanks to the consistent modular principle and innovative configuration software, your Hydromat® will be fully operational again in a very short time.

			HC 25-12	HC 32-16	HC 45-12 HC 45-16	HC 52-12	HC 12-U HC 16-U
<b>Workpiece size</b>	Bars, round	ø	25	32	45	52	-
	Blank, cubic	mm	35 x 35 x 50	50 x 60 x 60	50 x 60 x 60	50 x 60 x 60	120 x 120 x 120
	Workpiece length	mm	100	150	170   150	170	200   150
<b>Rotary indexing table</b>	Clamping stations	Number	12	16	12   16	12	12   16
	Indexing time	s	0.5	0.7	0.7	0.7	1.0
<b>Number Machining units</b>	Horizontal	Number	12	16	12   16	12	12   16
	Vertical		6	8	6   8	6	6   8
	Spindles/axes		18 / 99	24 / 99	18   24 / 99	18 / 99	18   24 / 99
<b>Travel paths</b>	X axis	mm	±8.5	±15	±15	±15	±30
	Y axis	mm	±12.5	±30	±30	±30	±30
	Z axis	mm	+100	+120	+120	+120	+120
<b>Standard layout</b>	Dimension L x W x H	m	8.9 x 3.3 x 2.9	8.9 x 3.3 x 2.9	8.9 x 3.3 x 2.9	14 x 4.8 x 3.0	5.7 x 4.0 x 2.9
	Machine weight	t	approx. 4	approx. 6	approx. 6.5	approx. 7	approx. 8
<b>Loading</b>	direct from the bar with loading magazine, up to 6 meters   from coil   load blank via load handling or robot						



### About FFG Europe & Americas

FFG Europe & Americas unite major players from the German, Italian, Swiss and American machine tool industry with a broad range of milling, turning, grinding, and gear manufacturing technology, and the knowhow of the renowned machine tool brands VDF Boehring, Hessapp, IMAS, Jobs, MAG, Meccanodora, Modul, Morara, Pffnner, Rambaudi, Sachman, Sigma, SMS, Tacchella and Witzig & Frank. Since 1798, these brands have substantially contributed to the progress in industrial manufacturing and are well known as reliable and innovative equipment and systems solutions suppliers for the automotive and truck, aerospace, machine building, general machining, railway industry, energy and heavy engineering industries. While being an independent group, these entities benefit from the strengths and opportunities of the global Fair Friend Group. They stand for premium technology within FFG.



### FFG Europe & Americas

K.R. Pffnner AG (Head office)  
Sonnmattstrasse 28  
CH-3427 Utzenstorf  
Tel. +41 32 6 66 35 35  
Fax +41 32 6 66 35 55

### FFG Europe & Americas

K.R. Pffnner GmbH  
Axtbuehl 2  
DE-78658 Zimmern o.R.  
Tel. +49 741 92 88 0  
Fax +49 741 92 88 155

### FFG Europe & Americas

FFG European & Americans  
Holdings GmbH  
Salacher Strasse 93  
DE-73054 Eislingen/Fils  
Tel. +49 71 61 805-0  
Fax +49 71 61 805-223

FFG Europe & Americas

info@ffg-ea.com

www.ffg-ea.com